



omegacrusher.com

Omega **J1065S** CRUSHING & SCREENING STATIC

Feeder

Width	940 mm (0.94 m)
Type	Vibrating feeder tray
Control	Variable speed

Hopper

Width	2500 mm
Length:	4200 mm
Hopper capacity	4.1 m ³

Crusher

Crusher type	Omega 1065 single toggle
Crusher opening	40" x 26" / 1000 mm x 650 mm
Max feed	21" / 530 mm
CSS range	2" - 5" / 50 mm - 130 mm
Motor	90 kW
Adjustment type	Hydraulic wedge
Auto control	Chamber level sensor
Jaw speed	Adjustable 280-310 rpm
Chamber construction	Bolted
Jaw reverse feature	
Grizzly aperture	

Product conveyor

Width	900 mm (0.9 m)
Speed	87 m / m
Stockpile height	3500 mm

Weight

26,700 kg

* Details may change on final specification

Contact us:

Unit 10a, Enterprise Park, Drumquin Rd, Castlederg,
Co. Tyrone, N. Ireland, BT81 7PX

T. +44 28 8167 8571 E. info@omegacrusher.com

Omega CRUSHING & SCREENING

J1065S STATIC

HIGH OUTPUT CAPACITY

EFFICIENT ELECTRIC DRIVE

MODULAR DESIGN

FITS IN CONTAINER FOR SHIPPING



eco drive



VIBRATING FEEDER

- 940 mm wide
- Declined feeder to assist material flow
- Stepped grizzly section
- Hardox lined wear plates
- Stepped grizzly section

HOPPER

- Hardox construction
- 4.1 m³ capacity

CONVEYOR

- 900 mm wide
- Powerful motorised head drum pulley

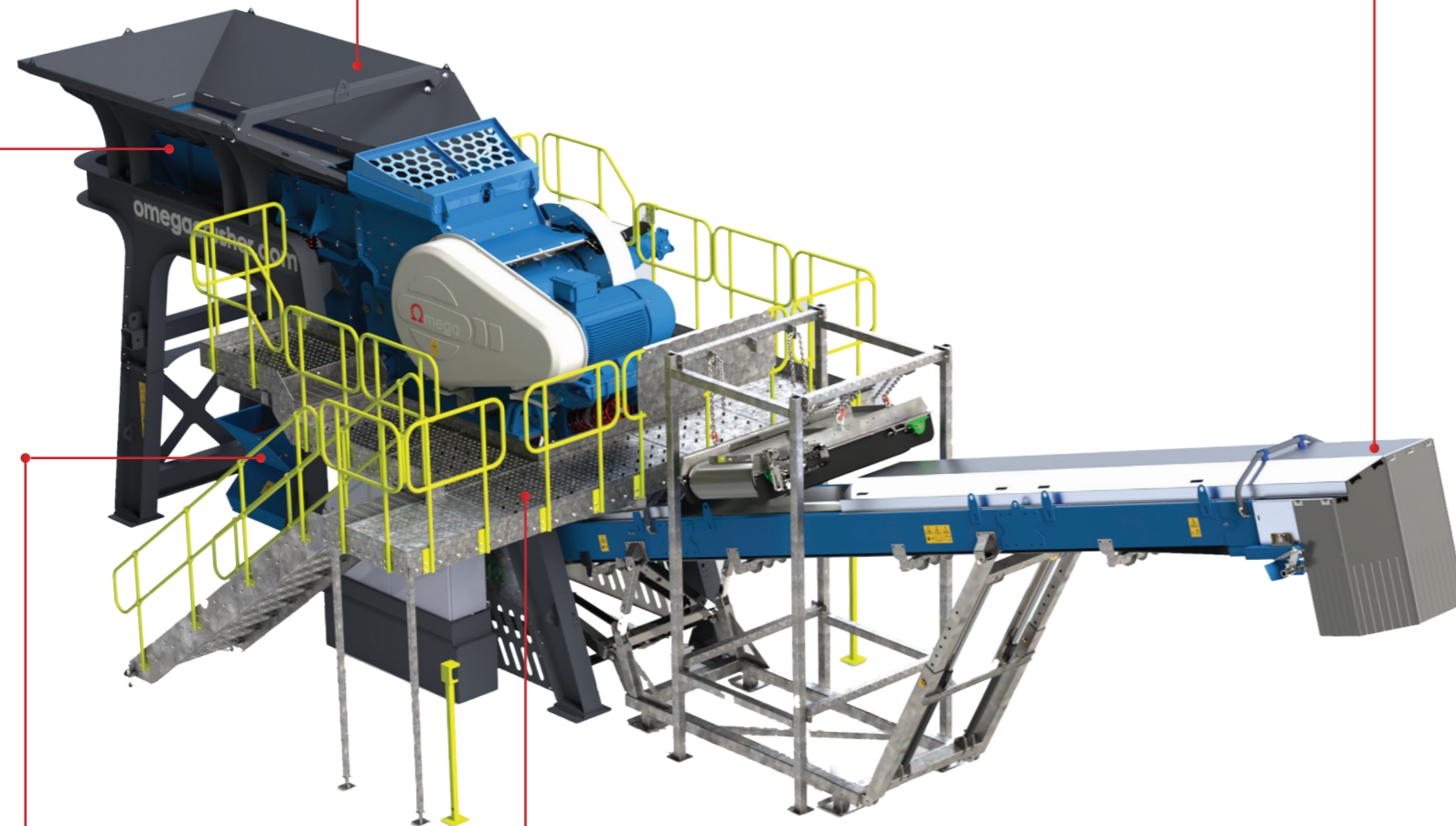

FINES CONVEYOR

- Motor / gearbox 22 kW
- Ply on belt Ep 500 3 Ply

FLOWFORGE FLOORING

- Galvanised walkway and handrails

Multiple Jaw die options

Hydraulic wedge for CSS adjust (50 - 130 mm)

Draw-back system for simplicity

Heavy duty shaft installed with premium bearings

Large 1000 mm x 650 mm feed opening

Weg motor electric drive via v-belt

Large Jaw ejector cylinder

Bolted mainframe for strength and durability

Optional deflector plate for recycling applications

WORKING DIMENSIONS

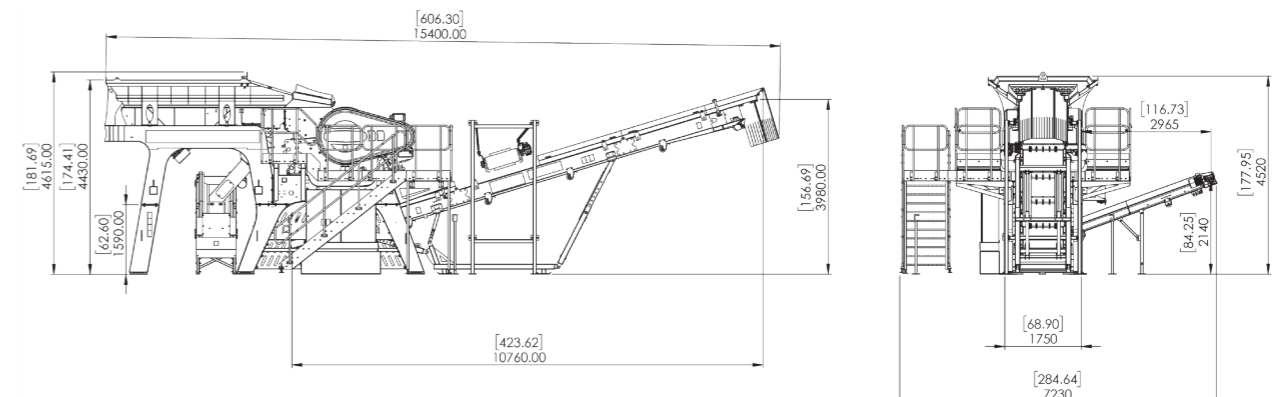

H. 4530 mm **W.** 7200 mm **L.** 15,400 mm **WEIGHT.** 26,700 kg